



Cambridge O Level

PHYSICS

3174/12

Paper 1 Multiple Choice

May/June 2021

1 hour

You must answer on the multiple choice answer sheet.

You will need: Multiple choice answer sheet
Soft clean eraser
Soft pencil (type B or HB is recommended)

INSTRUCTIONS

- There are **forty** questions on this paper. Answer **all** questions.
- For each question there are four possible answers **A, B, C** and **D**. Choose the **one** you consider correct and record your choice in soft pencil on the multiple choice answer sheet.
- Follow the instructions on the multiple choice answer sheet.
- Write in soft pencil.
- Write your name, centre number and candidate number on the multiple choice answer sheet in the spaces provided unless this has been done for you.
- Do **not** use correction fluid.
- Do **not** write on any bar codes.
- You may use a calculator.

INFORMATION

- The total mark for this paper is 40.
- Each correct answer will score one mark.
- Any rough working should be done on this question paper.

This document has **16** pages. Any blank pages are indicated.

1 When there is no wind, the engines of an airship push it due north at 20 m/s.

The wind is blowing from the west to the east at 12 m/s.

Which vector diagram shows how the resultant velocity R of the airship is obtained?

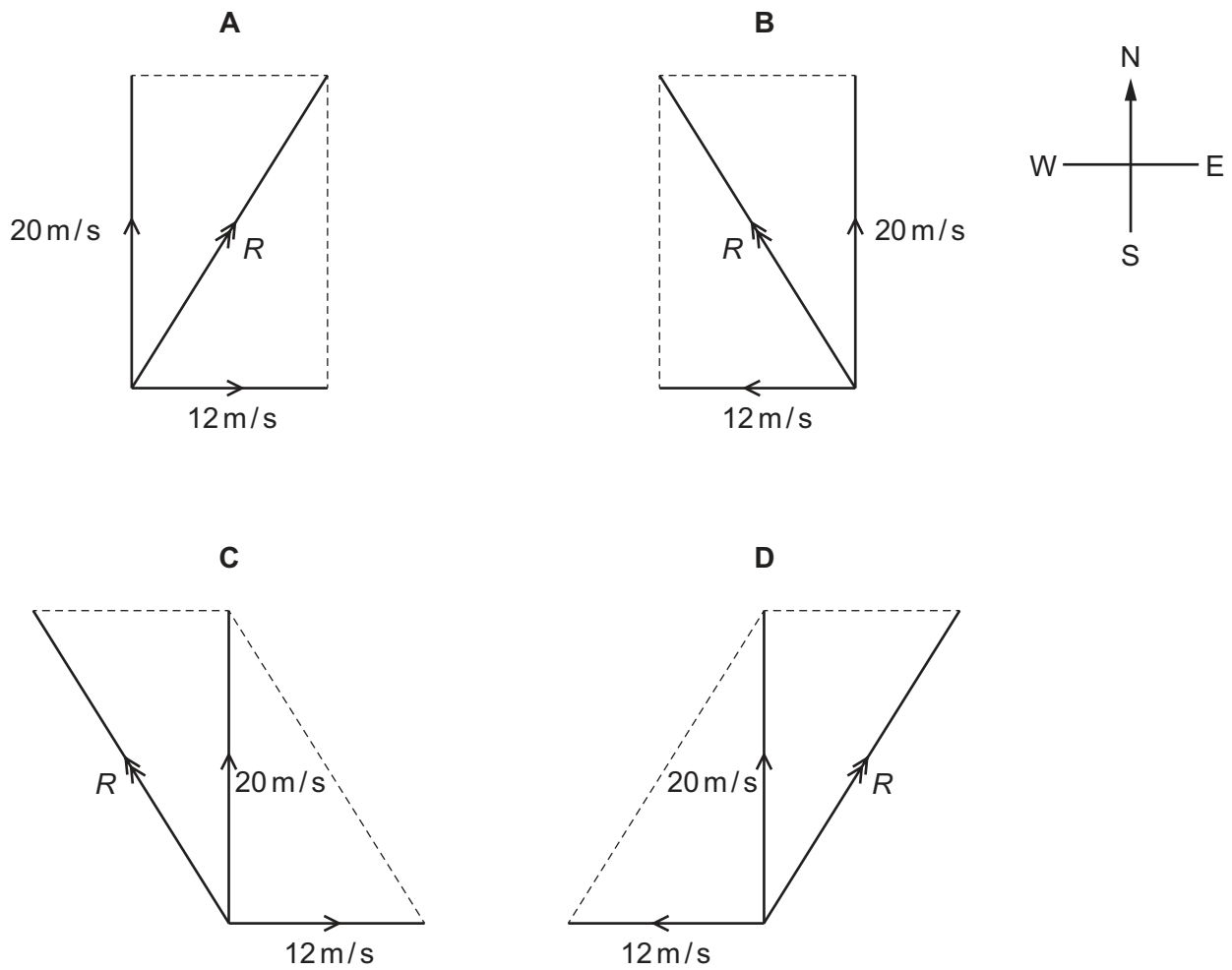

2 A student runs from point X to point Y.

Which quantity is a vector?

- A her average speed for the run
- B how long it takes to complete the run
- C the displacement of Y from X
- D the distance she runs

- 3 A stone is dropped from rest from the top of a ladder. It falls and hits the ground. It does not rebound.

Which speed–time graph is correct?

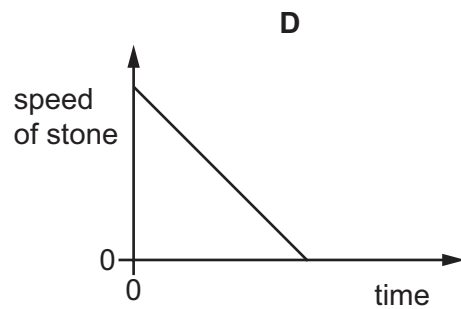
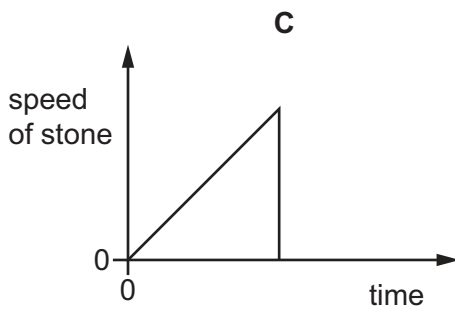
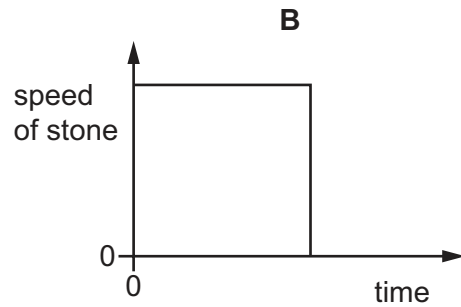
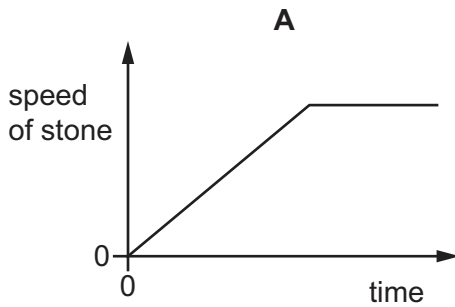

- 4 A student kicks a ball horizontally along the ground. As he does so, his foot applies a force to the ball.

At the same time, the ball applies a force to his foot.

How do these forces compare?

- A** The force on the foot is equal to the force on the ball and in the opposite direction.
B The force on the foot is equal to the force on the ball and in the same direction.
C The force on the foot is smaller than the force on the ball and in the opposite direction.
D The force on the foot is smaller than the force on the ball and in the same direction.

- 5 The diagram shows a parachutist falling towards Earth.

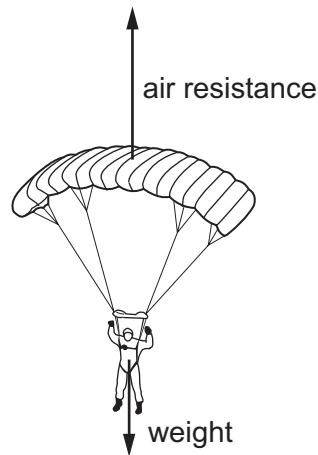

The lengths of the arrows represent the sizes of the forces on the parachutist and the parachute.

How is the parachutist moving at the instant shown?

- A accelerating downwards
 - B constant speed
 - C decelerating downwards
 - D decelerating upwards
- 6 The driver of a car sees a hazard in the road and applies the brakes to stop the car.
- Which quantity does **not** depend on the condition of the road?
- A the braking distance
 - B the average deceleration of the car as it brakes
 - C the force on the car causing deceleration
 - D the thinking distance
- 7 A satellite is in a circular orbit around a planet.
- Which statement is correct?
- A Its acceleration is constant in direction but not in size.
 - B Its acceleration is constant in size but not in direction.
 - C Its gravitational potential energy varies.
 - D Its velocity is constant.

- 8 Which property of an object resists a change in its state of rest or motion?
- A acceleration
B density
C mass
D velocity
- 9 An object of mass 10 kg falling freely in the gravitational field close to the Moon's surface has an acceleration of 1.6 m/s^2 .

What is the gravitational field strength on the Moon?

- A 0 N/kg B 1.6 N/kg C 10 N/kg D 16 N/kg
- 10 A measuring cylinder contains 50 small, dry metal spheres.
- When 25 cm^3 of water is poured into the cylinder, the meniscus is at the 60 cm^3 mark.
- What is the volume of one sphere?

- A $\frac{50-25}{60}$ B $\frac{50+25}{60}$ C $\frac{60-25}{50}$ D $\frac{60+25}{50}$

- 11 The total weight of the load and the wheelbarrow shown is 600 N.

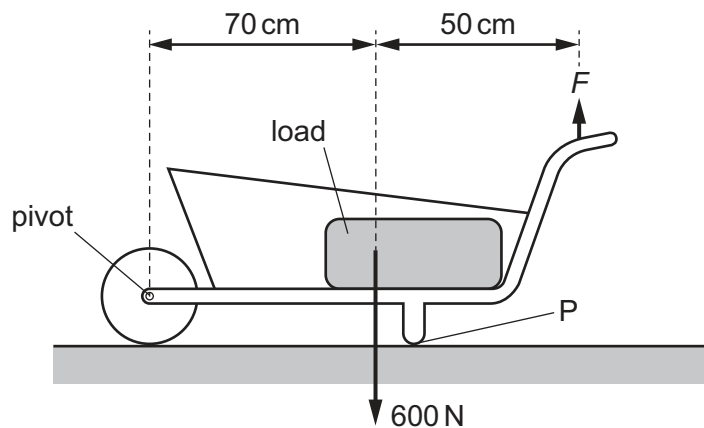

What is the size of the minimum force F needed to lift P off the ground?

- A 350 N B 430 N C 600 N D 840 N

- 12 A rectangular block of metal has weight 6.0 N and measures 3.0 cm × 4.0 cm × 5.0 cm.

The block rests on a horizontal surface. The face with the largest area is in contact with the surface.

What is the pressure exerted by the block on the surface?

- A 0.10 N/cm² B 0.30 N/cm² C 0.40 N/cm² D 0.50 N/cm²
- 13 The diagram shows an instrument that a student uses to determine atmospheric pressure.
- Which distance does the student use when calculating atmospheric pressure?

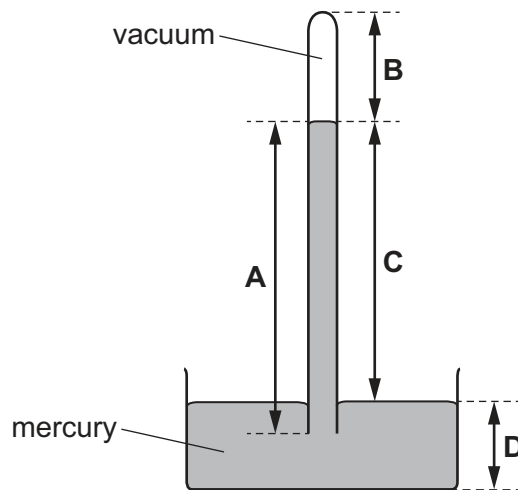

- 14 The diagrams show identical large tanks filled with water to different depths.

A diver is horizontal in each tank.

Which diver experiences the greatest pressure?

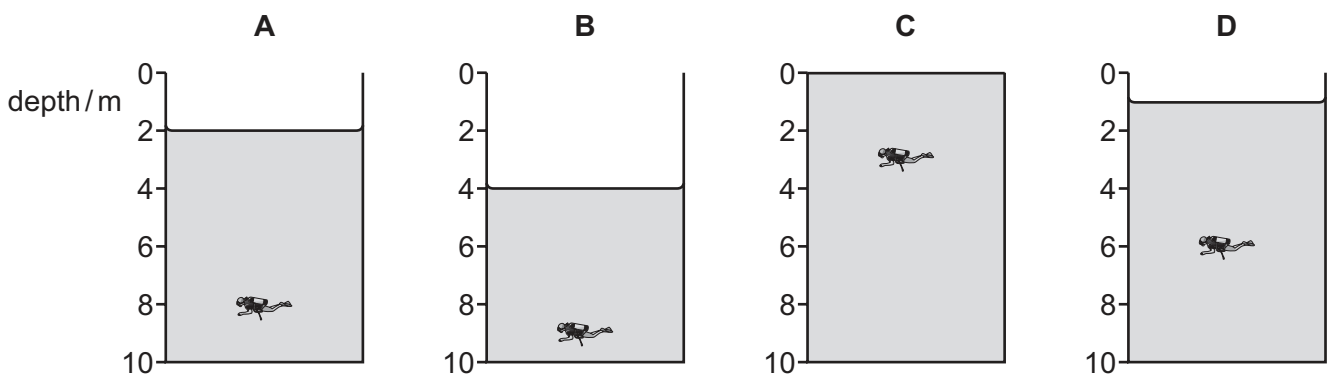

- 15 A student does an experiment in which she measures the volume of a fixed mass of gas at different pressures. The temperature of the gas remains constant.

Which graph shows her results?

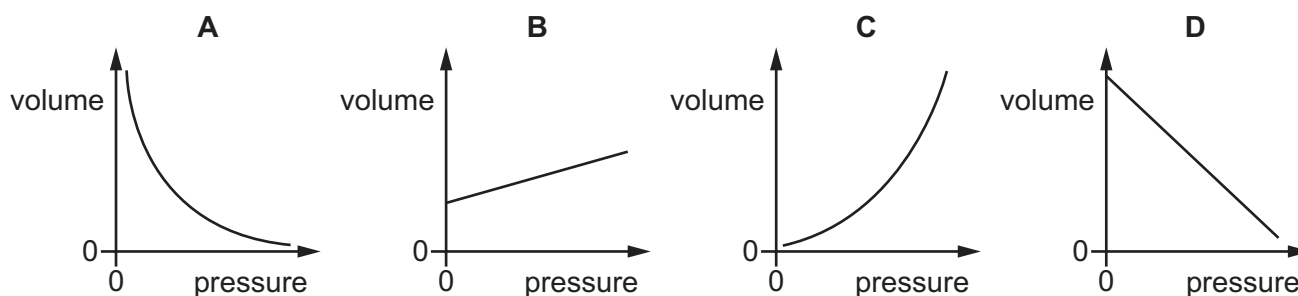

- 16 A crane moves its load diagonally, as shown.

By which distance is the weight of the load multiplied to calculate the change in gravitational potential energy of the load?

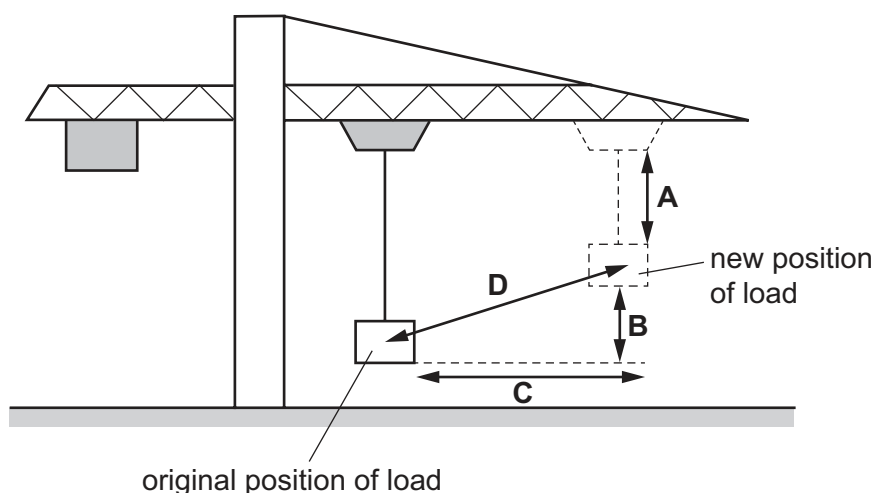

- 17 Two solar cells of equal area but different efficiencies are exposed to sunlight of different brightnesses for the same time.

Which statement applies to the more efficient cell when compared with the less efficient cell?

- A It generates less electrical energy from sunlight of greater brightness.
- B It generates less electrical energy from sunlight of the same brightness.
- C It generates the same electrical energy from sunlight of greater brightness.
- D It generates the same electrical energy from sunlight of lower brightness.

18 Four people run up the same set of steps.

Which person produces the most power?

	weight / N	time / s
A	500	3.0
B	500	5.0
C	900	3.0
D	900	5.0

19 Which expression describes thermal conduction in solids that are non-metallic?

- A** transfer of free molecules throughout the solids
- B** transfer of vibrations between neighbouring molecules
- C** transfer of electrons between neighbouring molecules
- D** transfer of free electrons throughout the solids

20 Which type of thermometer is used to measure temperatures above 1000 °C, and which type is used to measure temperatures that change rapidly?

	to measure temperatures above 1000 °C	to measure temperatures that change rapidly
A	liquid-in-glass	liquid-in-glass
B	liquid-in-glass	thermocouple
C	thermocouple	liquid-in-glass
D	thermocouple	thermocouple

- 21 Two liquid-in-glass thermometers are almost identical. They contain the same quantity of the same liquid, and the diameters of their capillary tubes are the same.

The only difference is that one thermometer is longer than the other.

Which row shows how the ranges and the sensitivities of the thermometers compare?

	ranges	sensitivities
A	different	different
B	different	same
C	same	different
D	same	same

- 22 The graph shows how the temperature of a fixed amount of a material changes when heated at a constant rate.

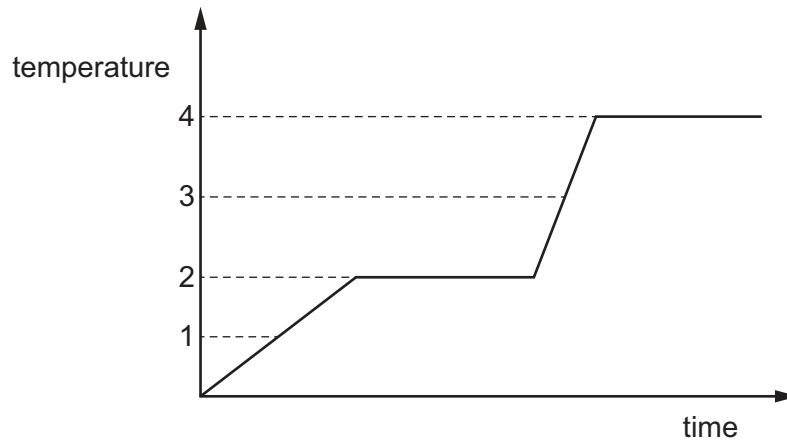

Which row shows the melting point and the boiling point of the material?

	melting point	boiling point
A	1	3
B	1	4
C	2	3
D	2	4

- 23** Initially, the molecules of a substance are close together. They move past each other and change position.

During a specific change of state, the molecules of the substance become slightly closer together and vibrate about fixed positions.

What is the change of state?

- A** boiling
- B** condensation
- C** melting
- D** solidification

- 24** A student writes three statements about what happens when the air in a balloon cools.

- 1 The molecules move closer together.
- 2 The molecules become smaller.
- 3 The mass of the molecules decreases.

Which statements are correct?

- A** 1 only
- B** 1 and 2 only
- C** 2 and 3 only
- D** 1, 2 and 3

- 25** A wave moves along a rope.

How do the particles of the rope vibrate as the wave passes?

- A** They all vibrate in exactly the same way and at the same time as each other.
- B** They all vibrate in exactly the same way but slightly out of step with neighbouring particles.
- C** They all vibrate with different periods.
- D** They all vibrate with different frequencies.

- 26** A plane mirror reflects a ray of light from an object, as shown.

At which position is the image of the object formed?

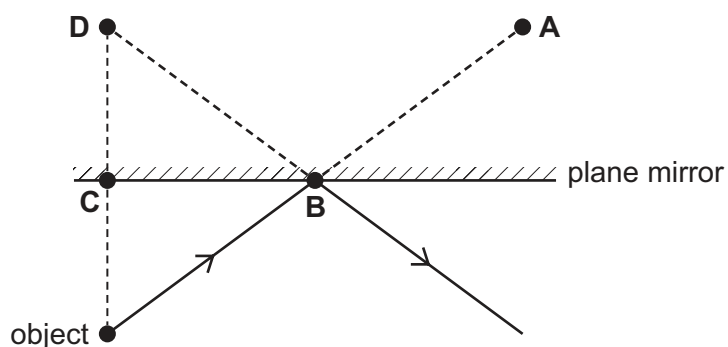

27 A piece of paper torn out of an exercise book is shown.

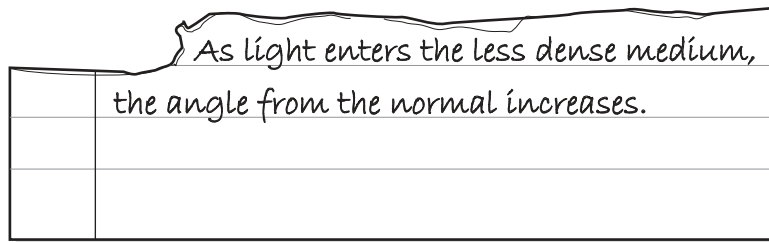

Which process must be taking place?

- A dispersion
- B magnification
- C reflection
- D refraction

28 The thin converging lens in a camera forms image YZ of object PQ.

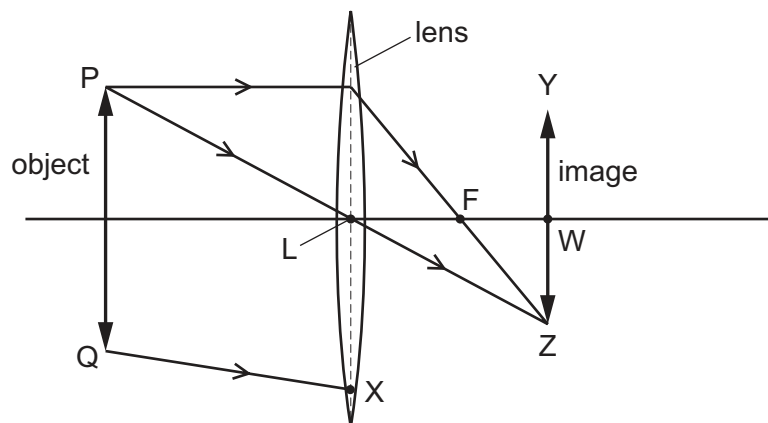

Distance LF is the focal length of the lens.

To which point does ray QX travel after passing through the lens?

- A F
- B W
- C Y
- D Z

29 Which statement about the image formed by a converging lens is correct?

- A It is always real and inverted.
- B It is always real and upright.
- C It is always virtual and upright.
- D It may be either virtual or real.

30 A student writes four statements about electromagnetic waves.

- 1 A medium is needed for their transmission.
- 2 Their speed in air is 3.0×10^5 km/s.
- 3 They are composed of electrons.
- 4 They produce ionisation when their wavelengths are very short.

Which statements are correct?

- A** 1 and 2 **B** 1 and 3 **C** 2 and 4 **D** 3 and 4

31 A loudspeaker produces four sounds of different frequencies.

- 1 1.0 Hz
- 2 10 Hz
- 3 1.0 kHz
- 4 10 kHz

Which sounds are audible for a healthy human ear?

- A** 1 and 2 **B** 2, 3 and 4 **C** 3 and 4 only **D** 4 only

32 A sound wave passes through three different mediums arranged next to each other.

The speed of the sound wave decreases as it passes from the first medium to the second and then increases as it passes from the second medium to the third.

In which order does the sound wave travel through the mediums?

- A** gas → liquid → solid
B liquid → solid → gas
C solid → gas → liquid
D solid → liquid → gas

- 33 A soft iron bar and a steel bar each have a coil of wire wound around them.

Each coil is connected to a battery and a switch.

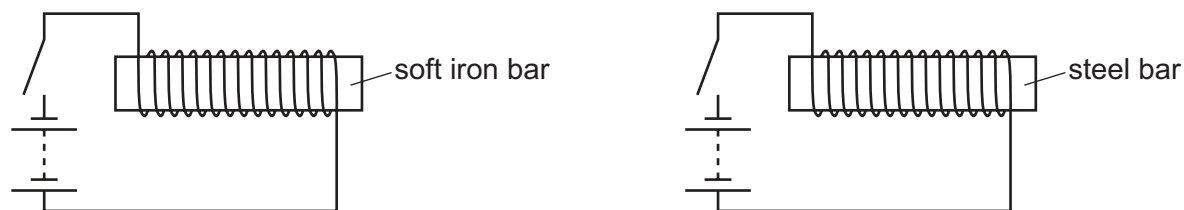

The switches in both circuits are closed and iron nails are held close to each of the bars.

Both switches are then opened and iron nails are held close to each of the bars again.

Which bars attract the nails when the switches are closed, and which bars attract the nails after the switches are opened?

	while switches are closed	after switches are opened
A	both bars attract nails	only soft iron bar attracts nails
B	both bars attract nails	only steel bar attracts nails
C	only soft iron bar attracts nails	neither bar attracts nails
D	only steel bar attracts nails	neither bar attracts nails

- 34 In a photocopier, particles of ink are attracted to an area of a plate on which an excess of electrons are fixed in position.

Is the area of the plate with an excess of electrons a conductor or an insulator, and what is the charge on the particles of ink?

- A** The area is a conductor and the particles of ink are negatively charged.
- B** The area is a conductor and the particles of ink are positively charged.
- C** The area is an insulator and the particles of ink are negatively charged.
- D** The area is an insulator and the particles of ink are positively charged.
- 35 A student uses a multimeter to measure the current in a $4.7\text{ k}\Omega$ resistor connected to a 30 V source.

Which range of the multimeter is best?

- A** $0\text{--}1\text{ mA}$ **B** $0\text{--}10\text{ mA}$ **C** $0\text{--}100\text{ mA}$ **D** $0\text{--}1\text{ A}$

36 A car battery supplies a current of 5.0 A to the car's headlamps for 30 minutes.

What is the charge that flows in this time?

- A 2.5 C B 150 C C 360 C D 9000 C

37 Which graph shows how the resistance R of a constant length of wire depends on its cross-sectional area A ?

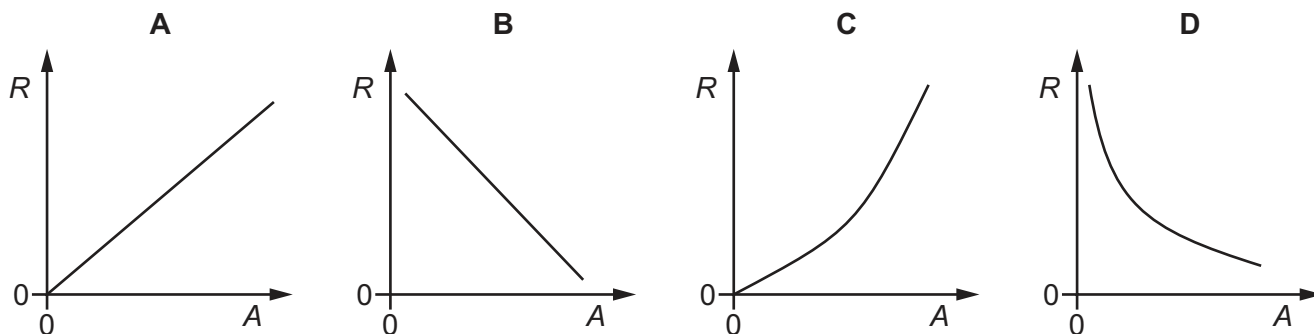

38 Two long, straight, parallel wires pass vertically through a horizontal board.

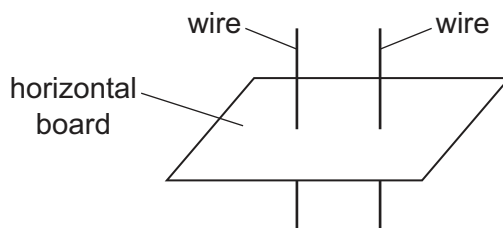

The two wires carry currents in the same direction. This produces forces on the wires.

What is the magnetic field pattern on the board, and do the wires attract or repel each other?

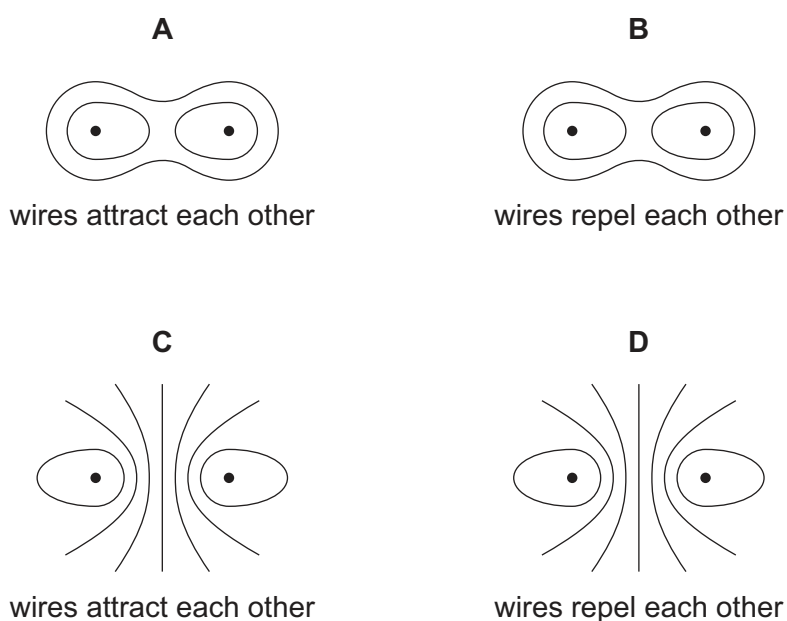

39 Which radioactive emissions are deflected when passing through both electric fields and magnetic fields?

- A** alpha-particles, beta-particles and gamma rays
- B** alpha-particles and beta-particles only
- C** alpha-particles and gamma rays only
- D** beta-particles and gamma rays only

40 A cloud of gas in space collapses to form a star which is stable for billions of years.

Which process releases energy in the star and prevents the star from further collapse?

- A** ionisation
- B** nuclear fission
- C** nuclear fusion
- D** radioactive decay

BLANK PAGE

Permission to reproduce items where third-party owned material protected by copyright is included has been sought and cleared where possible. Every reasonable effort has been made by the publisher (UCLES) to trace copyright holders, but if any items requiring clearance have unwittingly been included, the publisher will be pleased to make amends at the earliest possible opportunity.

To avoid the issue of disclosure of answer-related information to candidates, all copyright acknowledgements are reproduced online in the Cambridge Assessment International Education Copyright Acknowledgements Booklet. This is produced for each series of examinations and is freely available to download at www.cambridgeinternational.org after the live examination series.

Cambridge Assessment International Education is part of the Cambridge Assessment Group. Cambridge Assessment is the brand name of the University of Cambridge Local Examinations Syndicate (UCLES), which itself is a department of the University of Cambridge.